

**GOVERNMENT POLYTECHNIC,  
KENDRAPADA**

**DEPARTMENT OF CIVIL ENGINEERING**



**LECTURE NOTES**

**Year & Semester:-3<sup>RD</sup> year & 6<sup>th</sup> sem**

**Subject code &/Name:- TH-4 (a),  
Concrete Technology**

**BY: - Bhagabat Jena PTGF (CIVIL)**

## CEMENT:

A cement is a binder, a substance used for construction that sets, hardens, and adheres to other materials to bind them together. Cement is seldom used on its own, but rather to bind fine aggregate (sand) and coarse aggregate (gravel) together. Cement mixed with fine aggregate produces mortar for masonry, or with fine aggregate and coarse aggregate, produces concrete.

Concrete is the most widely used material in existence and is behind only water as the planet's most-consumed resource.

Cements used in construction are usually inorganic, often lime or calcium silicate based, which can be characterized as non-hydraulic or hydraulic respectively, depending on the ability of the cement to set in the presence of water. Non-hydraulic cement does not set in wet conditions or under water. Rather, it sets as it dries and reacts with carbon dioxide in the air. It is resistant to attack by chemicals after setting.

Hydraulic cements (e.g., Portland cement) set and become adhesive due to a chemical reaction between the dry ingredients and water. The chemical reaction results in mineral hydrates that are not very water-soluble and so are quite durable in water and safe from chemical attack. This allows setting in wet conditions or under water and further protects the hardened material from chemical attack. The chemical process for hydraulic cement was found by ancient Romans who used volcanic ash (pozzolana) with added lime (calcium oxide). The word "cement" can be traced back to the Ancient Roman term *opus cementicium* (Roman concrete, also called *opus cementicium*, was a material used in construction in Ancient Rome.

Roman concrete was based on a hydraulic-setting cement. It is durable due to its incorporation of pozzolanic ash, which prevents cracks from spreading), used to describe masonry resembling modern concrete that was made from crushed rock with burnt lime as binder. The volcanic ash and pulverized (reduce to fine particles) brick supplements that were added to the burnt lime, to obtain a hydraulic binder, were later referred to as *cementum*, *cimentum*, *cäment*, and *cement*. In modern times, organic

polymers are sometimes used as cements in concrete. World production is about four billion tonnes per year, of which about half is made in China. If the cement industry were a country, it would be the third largest carbon dioxide emitter in the world with up to 2.8 billion tonnes, surpassed only by China and the United States. The initial calcination reaction (at or above the thermal decomposition temperature) in the production of cement is responsible for about 4% of global CO<sub>2</sub> emissions. The overall process is responsible for about 8% of global CO<sub>2</sub> emissions, as the cement kiln in which the reaction occurs is typically fired by coal or petroleum coke due to the luminous flame required to heat the kiln by radiant heat transfer. As a result, the production of cement is a major contributor to climate change.

#### HYDRAULIC CEMENT:

By far the most common type of cement is hydraulic cement, which hardens by hydration of the clinker minerals when water is added. Hydraulic cements (such as Portland cement) are made of a mixture of silicates and oxides. The four main mineral phases of the clinker, abbreviated in the cement chemist notation, being:

C3S: Tri Calcium Silicate (Alite) ( $3\text{CaO}\cdot\text{SiO}_2$ );

C2S: Di Calcium Silicate (Belite) ( $2\text{CaO}\cdot\text{SiO}_2$ );

C3A: Tri Calcium Aluminate (celite) ( $3\text{CaO}\cdot\text{Al}_2\text{O}_3$ );

C4AF: Tetra Calcium Alumino Ferrite (Brownmillerite) ( $4\text{CaO}\cdot\text{Al}_2\text{O}_3\cdot\text{Fe}_2\text{O}_3$ ).

The silicates are responsible for the cement's mechanical properties — the tricalciumaluminate and Tetra Calcium Alumino Ferrite are essential for the formation of the liquid phase during the sintering (firing) process of clinker at high temperature in the kiln. The chemistry of these reactions is not completely clear and is still the object of research.

First, the limestone (calcium carbonate) is burned to remove its carbon, producing lime (calcium oxide) in what is known as a

calcination reaction. This single chemical reaction is a major emitter of global carbon dioxide emissions.

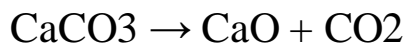

The lime reacts with silicon dioxide to produce dicalcium silicate and tricalcium silicate.

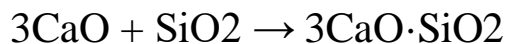
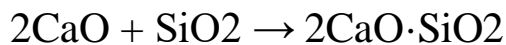

The lime also reacts with aluminum oxide to form tricalcium aluminate.

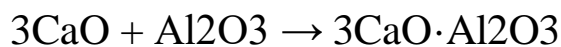

The lime also reacts together with aluminum oxide, and ferric oxide to form cement.



#### NON-HYDRAULIC CEMENT:

A less common form of cement is non-hydraulic cement, such as slaked lime (calcium oxide mixed with water), hardens by carbonation in contact with carbon dioxide, which is present in the air (~ 412 vol. ppm  $\approx$  0.04 vol. %). First calcium oxide (lime) is produced from calcium carbonate (limestone or chalk) by calcination at temperatures above 825 °C

(1,517 °F) for about 10 hours at atmospheric pressure:



The calcium oxide is then spent (slaked) mixing it with water to make slaked lime (calcium hydroxide):

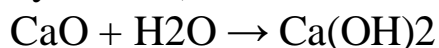

Once the excess water is completely evaporated (this process is technically called setting), the carbonation starts:

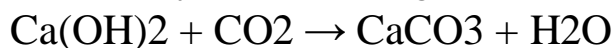

This reaction is slow, because the partial pressure of carbon dioxide in

the air is low (~ 0.4 millibar). The carbonation reaction requires that the dry cement be exposed to air, so the slaked lime is a non-hydraulic cement and cannot be used under water. This process is called the lime cycle.

#### PORTLAND CEMENT:

Portland cement, a form of hydraulic cement, is by far the most common type of cement in general use around the world. This cement is made by heating limestone (calcium carbonate) with other materials (such as clay) to 1,450 °C (2,640 °F) in a KILN, in a process known as calcination that liberates a molecule of carbon dioxide from the calcium carbonate to form calcium oxide, or quicklime, which then chemically combines with the other materials in the mix to form calcium silicates and other cementitious compounds. The resulting hard substance, called 'clinker', is then ground with a small amount of gypsum into a powder to make ordinary Portland cement, the most commonly used type of cement (often referred to as OPC). Portland cement is a basic ingredient of concrete, mortar, and most non-specialty grout. The most common use for Portland cement is to make concrete. Concrete is a composite material made of cement, aggregate (gravel and sand), and water. As a construction material, concrete can be cast in almost any shape, and once it hardens, can be a structural (loadbearing) element. Portland cement may be grey or white.

#### PORTLAND CEMENT BLEND:

Portland cement blends are often available as inter-ground mixtures from cement producers, but similar formulations are often also mixed from the ground components at the concrete mixing plant.

Portland blast-furnace slag cement, or blast furnace cement (ASTM C595 and EN 197-1 nomenclature respectively), contains up to 95% ground granulated blast furnace slag, with the rest Portland clinker and a little gypsum. All compositions produce high ultimate strength, but as slag content is increased, early strength is reduced, while sulphate resistance increases and heat evolution diminishes. Used as an economic alternative to Portland sulphate-resisting and low-heat

cements.

Portland-fly ash cement contains up to 40% fly ash under ASTM standards (ASTM C595), or 35% under EN standards (EN 197-1). The fly ash is pozzolanic, [Pozzolans are a broad class of siliceous and aluminous materials which, in themselves, possess little or no cementitious value but which will, in finely divided form and in the presence of water, react chemically with calcium hydroxide ( $\text{Ca(OH)}_2$ ) at ordinary temperature to form compounds possessing cementitious properties. The quantification of the capacity of a pozzolan to react with calcium hydroxide and water is given by measuring its pozzolanic activity. Pozzolana are naturally occurring pozzolans of volcanic origin. A siliceous volcanic ash used to produce hydraulic cement / Any of various powdered substances that react with lime to form strengthening or enhancing compounds in cement. Both natural (Volcanic ashes and pumices) and artificial (man-made, eg. metakaolin, fly ash, silica fume, rice husk ash, etc) materials show pozzolanic activity and are used as supplementary cementitious materials (SCM)], so that ultimate strength is maintained. Because fly ash addition allows a lower concrete water content, early strength can also be maintained. Where good quality cheap fly ash is available, this can be an economic alternative to ordinary Portland cement. Portland pozzolan cement includes fly ash cement, since fly ash is a pozzolan, but also includes cements made from other natural or artificial pozzolans. In countries where volcanic ashes are available (e.g., Italy, Chile, Mexico, the Philippines), these cements are often the most common form in use. The maximum replacement ratios are generally defined as for Portland-fly ash cement.

Portland silica fume cement. Addition of silica fume can yield exceptionally high strengths, and cements containing 5–20% silica fume are occasionally produced, with 10% being the maximum allowed addition under EN 197-1. However, silica fume is more usually added to Portland cement at the concrete mixer.[45] Masonry cements are used for preparing brick laying mortars and stuccos (decorative coating for walls and ceilings, exterior walls), and must not be used in concrete. They are usually complex proprietary

formulations containing Portland clinker and a number of other ingredients that may include limestone, hydrated lime, air entrainers, retarders, water proofers, and colouring agents. They are formulated to yield workable mortars that allow rapid and consistent masonry work. Subtle variations of masonry cement in North America are plastic cements and stucco cements. These are designed to produce a controlled bond with masonry blocks.

Expansive cements contain, in addition to Portland clinker, expansive clinkers (usually sulph-aluminate clinkers), and are designed to offset the effects of drying shrinkage normally encountered in hydraulic cements. This cement can make concrete for floor slabs (up to 60 m square) without contraction joints. White blended cements may be made using white clinker (containing little or no iron) and white supplementary materials such as high-purity met kaolin.

Colored cements serve decorative purposes. Some standards allow the addition of pigments to produce colored Portland cement. Other standards (e.g., ASTM) do not allow pigments in Portland cement, and colored cements are sold as blended hydraulic cements.

Very finely ground cements are cement mixed with sand or with slag or other pozzolan type minerals that are extremely finely ground together. Such cements can have the same physical characteristics as normal cement but with 50% less cement, particularly due to their increased surface area for the chemical reaction. Even with intensive grinding they can use up to 50% less energy (and thus less carbon emissions) to fabricate than ordinary Portland cements.

#### TYPES OF CEMENT (Other cements)

1. Ordinary Portland Cement (OPC)
2. Portland Pozzolana Cement (PPC)
3. Rapid Hardening Cement
4. Quick setting cement
5. Low Heat Cement
6. Sulfates resisting cement
7. Blast Furnace Slag Cement
8. High Alumina Cement
9. White Cement

10. Colored cement
  11. Air Entraining Cement
  12. Expansive cement
  13. Hydrographic cement
- Ordinary Portland Cement (OPC)

The principal raw materials used in the manufacture of Ordinary Portland Cement are:

1. Argillaceous or silicates of alumina in the form of clays and shales.
2. Calcareous or calcium carbonate, in the form of limestone, chalk and marl which is a mixture of clay and calcium carbonate.

The ingredients are mixed in the proportion of about two parts of calcareous materials to one part of argillaceous materials and then crushed and ground in ball mills in a dry state or mixed in wet state. The dry powder or the wet slurry is then burnt in a rotary kiln at a temperature between 1400 degree C to 1500-degree C. the clinker obtained from the kiln is first cooled and then passed on to ball mills where gypsum is added and it is ground to the requisite fineness according to the class of product.

**Portland Pozzolana Cement (PPC):**

Portland Pozzolana cement is integrated cement which is formed by synthesising (combining) OPC cement with pozzolanic materials in a certain proportion. It is commonly known as PPC cement. In this article we discuss about the properties, manufacture, characteristics, advantages and disadvantages of Portland Pozzolana cement.

**Rapid Hardening Cement:**

Rapid hardening cement is a particular type of cement that is used in exceptional cases of concrete pouring. As the name implies, rapid hardening cement needs the shortest time to set up and consolidate. It achieves higher strength on lesser days. With such, it can attain seven days strength in only three days.

**Quick setting cement:**

Quick Setting Cement (QSC) is a special cement formulation that develops a rapid compressive strength and significantly reduces the waiting on cement (WOC) time compared to traditional cement systems. This cement loses its plasticity quicker than ordinary Portland cement, but does not achieve a higher rate of strength.

**Low Heat Cement:**

Low heat cement is a special tailored cement which generates low heat of hydration during setting. It is manufactured by modifying the chemical composition of normal Portland cement. In this article we discuss about the composition, properties, characteristics, uses and advantages of low heat cement.

**Sulphate resisting cement:**

The sulphate resisting cement is the cement which has the capability to resist against sulphate attack by introducing low C<sub>3</sub>A and relatively low C<sub>4</sub>AF content in the cement. The specification for sulphate cement content should not allow C<sub>3</sub>A content more than 5 percent.

**Blast Furnace Slag Cement:**

Blast furnace slag cement is the mixture of ordinary Portland cement and fine granulated blast furnace slag obtained as a by-product in the manufacture of steel with percent under 70% to that of cement.

**Ground granulated blast furnace slag cement**

(GGBFS) is a fine glassy granule which contain cementitious properties.

**High Alumina Cement:**

High alumina cement refers to a fast-hardening, high-strength, heat-resistant and corrosion-resistant cementitious material. All clinker based on calcium aluminate and alumina content of about 50% and ground hydraulic cementitious material are called high alumina cement.

### White Cement:

The manufacturing process of white cement is same as that of grey cement, but the selection of raw material is an important part in the manufacturing process. The oxides of chromium, manganese, iron, copper, vanadium, nickel and titanium imparts the grey colour to the cement. In white cement manufacture, these raw materials are kept to least percentage. Limestone and clay are used as a prominent raw material for the manufacture of white cement. The manufacture process is same as that of OPC cement, the only differences are the heat required for the burning of raw material is more and fineness is more.

### Coloured cement:

Coloured Cement may be obtained by intimately mixing mineral pigments with ordinary cement. The amount of colouring material may vary from 5 to 10 per cent. If this percentage exceeds 10 per cent, the strength of cement is affected.

1. The chromium oxide gives green colour.
2. The cobalt imparts blue colour.
3. The iron oxide in different proportions gives brown, red or yellow colour
4. The manganese oxide is used to produce black brown coloured cement.

The coloured cements are widely used for finishing of floors, external surfaces. artificial marble, window sill slabs, textured panel faces, stair treads, etc.

### Air Entraining Cement:

Air-entrained Portland cement is a special cement which has air bubbles introduced in the cement or concrete that provides the space for expansion of minute droplets of water in the concrete due to freezing and thawing and protects from cracks and damage of concrete. In this article we discuss about manufacture, air entraining agents, properties, advantages and disadvantages.

### Advantages of Air-Entrained Cement

- Workability of concrete increases.
- Use of air entraining agent reduces the effect of freezing and thawing.
- Bleeding, segregation and laitance in concrete reduces.
- Entrained air improves the sulphate resisting capacity of concrete.
- Reduces the possibility of shrinkage and crack formation in the concrete surface.

### Expansive cement:

Expansive cement is special type of cement when mixed with water, which forms a paste that tends to increase in volume to a significantly greater degree than Portland cement paste after setting. The expansion of the cement mortar or concrete is compensated for the shrinkage losses. In this article we study about the manufacture, properties, types and uses of expansive cement.

### Hydrographic cement:

Hydrographic cement Hydrographic cement prepares by mixing water-repelling chemicals and has high workability and strength. It has the property of repelling water and unaffected during monsoon or rains. Hydrophobic cement mainly uses for the construction of water structures such as dams, water tanks, spillways, water retaining structures, etc.

### BOGUES COMPOUNDS:

When water is added to cement, it react with the ingredients of the cement chemically and results in the formation of complex chemical compounds terms as BOGUES compounds.

1. Tri-Calcium Aluminate ( $3\text{CaO} \cdot \text{Al}_2\text{O}_3$  or C3A) -----  
---8-12%
2. Tetra Calcium Alumino Ferrate ( $4\text{CaO} \cdot \text{Al}_2\text{O}_3 \cdot \text{Fe}_2\text{O}_3$  or C4AF)----  
----6-10%
3. Tri-Calcium Silicate ( $3\text{CaO} \cdot \text{SiO}_2$  or C3S)-----  
--30-50%
4. Di-Calcium Silicate ( $2\text{CaO} \cdot \text{SiO}_2$  or C2S)-----  
---20-45%

1. Tri-Calcium Aluminate ( $3\text{CaO} \cdot \text{Al}_2\text{O}_3$  or C3A)

Formed in 24 hrs of addition of Maximum evolution of heat of hydration Check setting time of cement

2. Tetra Calcium Alumino Ferrate ( $4\text{CaO} \cdot \text{Al}_2\text{O}_3 \cdot \text{Fe}_2\text{O}_3$  or C4AF)

Formed within 24 hrs of addition of water High heat of hydration in initial periods

3. Tri-Calcium Silicate ( $3\text{CaO} \cdot \text{SiO}_2$  or C3S)

Formed within week Responsible for initial strength of cement  
Contribute about 50-60% of strength Content increase for the pre-fabricated concrete construction, Cold weathering construction.

4. Di-Calcium Silicate ( $2\text{CaO} \cdot \text{SiO}_2$  or C2S)

Last compound formed during hydration of cement Responsible for progressive later stage strength Structure requires later stages strength proportion of this component increase e.g. hydraulic structures, bridges .water

### HYDRATION OF CEMENT:

When cement, water, aggregate, and additives are mixed together, a significant heat increase occurs. This is due to the exothermic process in the reaction between cement and water (called dehydration).

Measuring the concrete temperature over time enables you to know how far the concrete is in the hydration process (Concrete Maturity) and thereby also an estimated concrete strength. The hydration process is divided into five phases:

Phase 1: Initial Mixing Reaction Initial after mixing the cement and water comes into contact with each other, a peak in temperature happens. The aluminate (C3A) reacts with  $\text{H}_2\text{O}$  (Calcium and sulfate

ions) to form ettringite (aluminum hydroxide). The release of the energy from these reactions causes the initial peak.

### Phase 2: Dormancy

A result of the reaction described in phase 1 is a surface coating of the cement particles. This coating keeps increasing, but also slows down the reaction (hydration) as the access to H<sub>2</sub>O isn't as good as when the concrete was mixed. The amount of hydrated concrete keeps increasing on a steady level while the surface of the concrete keeps fluid. This is why this phase is used for transporting and pouring the concrete, as the concrete stays on a fluid level. The length of this period depends on each individual concrete mix and can, therefore, be optimized depending on the application like winter concreting, length of transport, etc. This phase ends with an initial set of the concrete.

### Phase 3: Strength Acceleration

A heat increase happens due to the reaction between calcium silicate (C<sub>3</sub>S and C<sub>2</sub>S) which creates the silicate hydrate CSH (heat increase also caused by other minor reactions). The creation of CSH also has a major impact on the concrete strength during this phase. In the case of for example mass concrete application, it can be very important to monitor the internal temperature variances, as the concrete temperature during this phase can increase rapidly to reach internal temperatures like 70-80°C (in some cases even higher). It is normally not recommended to exceed temperatures at around 70°C.

### Phase 4: Speed reduction

A maximum temperature has now been reached and the availability of free particles is now reduced and therefore slows down the temperature increase. This phase often ends with the desired strength and the formwork around the concrete can now be removed. Monitoring of concrete maturity and temperature and therefore enable the user with the exact time where this is possible.

## Phase 5: Steady Development / Post Formwork

The hydration process is now slowed down and will continue slowly to finish the remaining available cement and water particles. The formwork is now often removed and the concrete will now over time (can take a long time) finish the hydration process and reach final strengths (can take weeks or months).

Testing of cements:

Laboratory Tests of Cement:

1. Fineness Test
2. Consistency Test
3. Setting Time Test
4. Strength Test
5. Soundness Test
6. Heat of Hydration Test
7. Tensile Strength Test
8. Chemical Composition Test

Fineness test on cement

The fineness of cement is responsible for the rate of hydration, rate of evolution of heat and the rate of gain of strength. Finer the grains more is the surface area and faster the development of strength. The fineness of cement can be determined by Sieve Test or Air Permeability test.

Sieve Test: Air-set lumps are broken, and the cement is sieved continuously in a circular and vertical motion for a period of 15 minutes. The residue left on the sieve is weighed, and it should not exceed 10% for ordinary cement. This test is rarely used for fineness.

Air Permeability Test: Blaine's Air Permeability Test is used to find the specific surface, which is expressed as the total surface area in sq.cm/g. of cement. The surface area is more for finer particles.

### Consistency test on cement

This test is conducted to find the setting times of cement using a standard consistency test apparatus, Vicat's apparatus.

Standard consistency of cement paste is defined as that water content which will permit a Vicat plunger of 10 mm diameter and 50 mm length to penetrate depths of 33-35 mm within 3-5 minutes of mixing.

The test has to undergo three times, each time the cement is mixed with water varying from 24 to 27% of the weight of cement.

This test should be conducted at a constant temperature of 25°C or 29°C and at a constant humidity of 20%.

### Setting Time of cement

Vicat's apparatus is used to find the setting times of cement i.e., initial setting time and final setting time.

**Initial Setting Time:** For this test, a needle of 1 mm square size is used. The needle is allowed to penetrate into the paste (a mixture of water and cement as per the consistency test). The time taken to penetrate 33-35 mm depth is recorded as the initial setting time.

**Final Setting Time:** After the paste has attained hardness, the needle does not penetrate the paste more than 0.5 mm. The time at which the needle does not penetrate more than 0.5 mm is taken as the final setting time.

### Strength test of cement

The strength of cement cannot be defined directly on the cement.

Instead the strength of cement is indirectly defined on cement-mortar of 1:3. The compressive strength of this mortar is the strength of cement at a specific period.

### Soundness test of cement

This test is conducted in Le Chatelier's apparatus to detect the presence of uncombined lime and magnesia in cement.

### Heat of Hydration Test

During the hydration of cement, heat is produced due to chemical reactions. This heat may raise the temperature of concrete to a high temperature. This test is carried out using a calorimeter adopting the principle of determining heat gain. It is concluded that Low-heat cement should not generate 65 calories per gram of cement in 7 days and 75 calories per gram of cement in 28 days true of 50°C. To avoid these, in large scale constructions low-heat cement has to be used.

### Tensile Strength of Cement

This test is carried out using a cement-mortar briquette in a tensile testing machine. A 1:3 cement-sand mortar with the water content of 8% is mixed and moulded into a briquette in the mould.

This mixture is cured for 24 hours at a temperature of 25°C or 29°C and in an atmosphere at 90% relative humidity. The average strength for six briquettes tested after 3 and 7 days is recorded.

### Chemical Composition Test

Different tests are conducted to determine the amount of various constituents of cement. Their requirements are based on IS: 269-1998, is as follows:

- The ratio of the percentage of alumina to that of iron oxide should not be less than 0.66.
- Lime Saturation Factor (LSF), i.e., the ratio of the percentage to that of alumina, iron oxide and silica should not be less than 0.66 and not be greater than 1.02.
- Total loss on ignition should not be greater than 4%.
- Total sulphur content should not be greater than 2.75%.
- Weight of insoluble residue should not be greater than 1.50%.
- Weight of magnesia should not be greater than 5%.

## Field Tests of Cement

The following tests should undergo before mixing the cement at construction sites:

### Colour Test of Cement

The colour of the cement should not be uneven. It should be a uniform grey colour with a light greenish shade.

### Presence of Lumps

The cement should not contain any hard lumps. These lumps are formed by the absorption of moisture content from the atmosphere. The cement bags with lumps should be avoided in construction.

### Cement Adulteration Test

The cement should be smooth if you rubbed it between fingers. If not, then it is because of adulteration with sand.

### Float Test

The particles of cement should flow freely in water for some time before it sinks.

### Date of Manufacturing

It is very important to check the manufacturing date because the strength of cement decreases with time. It's better to use cement before 3 months from the date of manufacturing.

# Chapter 8. Hardened Concrete

## 8.1 Introduction.

Fully cured, hardened concrete must be strong enough to withstand the structural and service loads which will be applied to it and must be durable enough to withstand the environmental exposure for which it is designed. If concrete is made with high-quality materials and is properly proportioned, mixed, handled, placed and finished, it will be the strongest and durable building material.

Concrete is a highly complex heterogeneous material whose response to stress depends not only on the response of the individual components but also upon the interaction between those components.

## 8.2 Properties of Hardened Concrete

The properties which determine the quality of the hardened concrete broadly fall into the following three groups:

- **Strength.**
- **Dimensional stability.**
- **Durability.**

## 8.3 Strength

Strength of concrete is its resistance to rupture. It may be measured in a number of ways, such as, strength in compression, in tension, in shear or in flexure. All these indicate strength with reference to a particular method of testing. When concrete fails under a compressive load the failure is essentially a mixture of crushing and shear failure. There are several factors affecting the strength of concrete as follows:

### 1- Concrete constituents and mix proportions:

- a- **Cement** (type, amount, cement fineness, etc.)
- b- **Aggregates** (type, MSA, FM, surface area, unit weight, aggregate grading, inertness, aggregate/cement ratio, fine aggregates/coarse aggregates, etc.)
- c- **Mixing water** (type, amount, water/cement ratio, etc.)
- d- **Admixtures** (type, dosage, chemical effectiveness, etc.)

### 2- Concrete production: (batching, mixing, transporting, casting, compaction).

### 3- Concrete curing: (curing method, temperature, degree of humidity, curing period).

### 4- Concrete age and testing conditions: (shape and size of specimen, loading rate, loading direction, saturation of specimen, specimen contact surface with the machine, etc.).

### 8.3.1 Compressive Strength

The compressive strength of concrete is one of the most important and useful properties of concrete. In most structural applications concrete is employed primarily to resist compressive stresses. Therefore, the concrete making properties of various ingredients of mix are usually measured in terms of the compressive strength.

Compressive strength is also used as a qualitative measure for other properties of hardened concrete. No exact quantitative relationship between compressive strength and flexural strength, tensile strength, modulus of elasticity, wear resistance, fire resistance, or permeability have been established. However, approximate or statistical relationships, in some cases, have been established and these give much useful information to engineers.

The compressive strength of concrete is generally determined by testing cubes or cylinders made in laboratory or field or cores drilled from hardened concrete at site or from the non-destructive testing of the specimen or actual structures.

#### Stress-Strain Relationship of Concrete

Stress strain curve of concrete is a graphical representation of concrete behavior under load. It is produced by plotting concrete compress strain at various interval of concrete compressive loading (stress). Concrete is mostly used in compression that is why its compressive stress strain curve is of major interest.

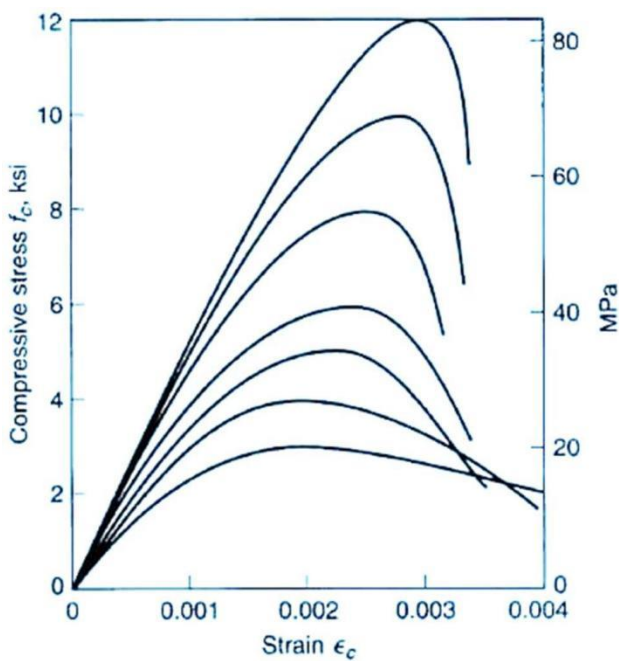

Figure 1

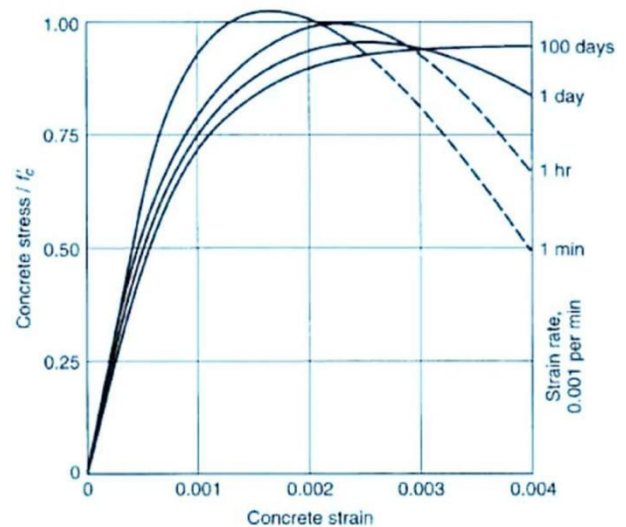

Figure 2

Figure 1 shows strain stress curve for normal weight concrete. There is a set of curves which represents the strength of the concrete. So, higher curves show higher concrete strength. Figure 2 shows how the shape of concrete stress strain curve changes based on the speed of loading.

### **1- Straight or Elastic Portion**

Initially, all stress strain curves in Figure 1 are fairly straight; stress and strain are proportional. With this stage, the material should be able to retain its original shape if the load is removed. The elastic range of concrete stress strain curve continues up to  $0.45f_c'$  (maximum concrete compressive strength).

The slope of elastic part of stress strain curve is concrete modulus of elasticity. The modulus of elasticity of concrete increases as its strength is increased. Design Codes provide equations for computing concrete modulus of elasticity.

### **2. Peak Point or Maximum Compress Stress Point**

When a load is further increased, the elastic range is exceeded and concrete begin to show plastic behavior (Nonlinear). After elastic range, the curve starts to horizontal; reaching maximum compress stress (maximum compressive strength).

For normal weight concrete, the maximum stress is realized at compressive strain ranges from 0.002 to 0.003. For normal weight concrete, the ACI Code specified that, a strain of 0.003 is maximum strain that concrete can reach and this value used for design of concrete structural element. However, the European Code assumes concrete can reach a strain of 0.0035, and hence this value is used for the design of concrete structural element.

### **3. Descending Portion**

After reaching maximum stress, all the curves show descending trend. The characteristics of the stress strain curve in descending part is based on the method of testing.

#### **8.3.2 Tensile Strength**

Plain concrete (without steel reinforcement) is quite weak in tensile strength which may vary from 0.05 to 0.125 % of the ultimate compressive strength. It is primarily for this reason that steel bars (reinforcement) are introduced into the concrete to get very strong concrete in compression as well as in tension.

### **8.3.3 Shear Strength**

Shear strength of concrete is taken approximately equal to 20 % its compressive strength

### **8.3.4 Bond Strength**

The strength of bond between steel reinforcement and concrete is called as bond strength of concrete. Bond strength develops primarily due to friction and adhesion between steel reinforcement and concrete.

In general, bond strength is approximately proportional to the compressive strength of concrete up to about 20 MPa (3000 psi). For higher compressive strengths of concrete, the increase in bond strength becomes progressively smaller and eventually negligible.

### **8.3.5 Impact Strength**

Impact strength of concrete is of importance in driving concrete piles, in foundations for machines exerting impulsive loading, and also when accidental impact is possible, e.g. when handling precast concrete members.

Some researchers have found that impact is related to the compressive strength, and it has been suggested that the impact strength varies from 0.50 to 0.75 of the compressive cube strengths.

### **8.3.6 Fatigue Strength**

The strength of concrete against cyclic or repeated loading is called as its fatigue strength. The fatigue strength of concrete is much less than that from static strength due to sustained loading. A fatigue limit of (50-60) % of compressive strength in static, is observed, when stress is applied in 2,000,000 cycle, for a maximum stress starting from zero.

## **8.4 Types of Concrete Testing**

During construction, an estimate of the in-place strength of concrete may be desired for determining the safe time to strip forms or to proceed with further work. The adequacy of mix proportions may need to be verified. Compressive strength data is necessary for quality control.

The measured results are dependent upon adhering strictly to standardized uniform procedures. Most testing errors produce lower strength results.

Testing concrete is classified into two types based on whether destructive stresses are applied or not.

- **Destructive Testing**
- **Non-Destructive Testing (NDT)**

### 8.4.1 Destructive Testing

Destructive testing of concrete samples involves applying direct stresses (compression, tensile, flexural, etc.) on representative concrete samples, after which these samples became destroyed.

#### Variables that Influence Measured Concrete Compressive Strength

- ❖ Sampling
- ❖ Casting
- ❖ Initial Curing
- ❖ Transporting
- ❖ Laboratory Curing
- ❖ Capping
- ❖ Testing (moisture condition and temperature, loading rate, specimen misalignment, seating behavior, machine calibration, post-failure inspection)
- ❖ Reporting

### 8.4.2 Non-Destructive Testing of Concrete

The standard method of evaluating the quality of concrete in buildings or structures is to test specimens cast simultaneously for compressive, flexural and tensile strengths. The main disadvantages are that results are not obtained immediately. Concrete in specimens may differ from that in the actual structure as a result of different curing and compaction conditions. Further, strength properties of a concrete specimen depend on its size and shape.

Therefore, several non - destructive methods (NDT) of assessment have been developed. These depend on the fact that certain physical properties of concrete can be related to strength and can be measured by non-destructive methods. Such properties include hardness, resistance to penetration by projectiles, rebound capacity and ability to transmit ultrasonic pulses and X- and Y-rays.

These non-destructive methods may be categorized as:

- 1- penetration tests
- 2- rebound tests
- 3- pull-out techniques
- 4- dynamic tests
- 5- radioactive tests,

These methods are briefly described below including their advantages and disadvantages.

## Penetration Tests

The Windsor probe is generally considered to be the best means of testing penetration. Equipment consists of a powder-actuated gun or driver, hardened alloy probes, loaded cartridges, a depth gauge for measuring penetration of probes and other related equipment.

Limitations and Advantages. The probe test produces quite variable results and should not be expected to give accurate values of concrete strength. It has, however, the potential for providing a quick means of checking quality and maturity of in situ concrete. It also provides a means of assessing strength development with curing.





## **Rebound Tests**

The rebound hammer is a surface hardness tester for which an empirical correlation has been established between strength and rebound number. The only known instrument to make use of the rebound principle for concrete testing is the Schmidt hammer.

*Limitations and Advantages.* The Schmidt hammer provides an inexpensive, simple and quick method of obtaining an indication of concrete strength, but accuracy of  $\pm 15$  to  $\pm 20$  per cent is possible only for specimens cast cured and tested under conditions for which calibration curves have been established. The results are affected by factors such as smoothness of surface, size and shape of specimen, moisture condition of the concrete, type of cement and coarse aggregate, and extent of carbonation of surface.



## **Pull-Out Tests**

A pull-out test measures, with a special ram, the force required to pull from the concrete a specially shaped steel rod whose enlarged end has been cast into the concrete to a depth of 3 in. (7.6 cm). The concrete is simultaneously in tension and in shear, but the force required to pull the concrete out can be related to its compressive strength. The pull-out technique can thus measure quantitatively the in-situ strength of concrete when proper correlations have been made.

**Limitations and Advantages.** Although pullout tests do not measure the interior strength of mass concrete, they do give information on the maturity and development of strength of a representative part of it. Such tests have the advantage of measuring quantitatively the strength of concrete in place. Their main disadvantage is that they have to be planned in advance and pull-out assemblies set into the formwork before the concrete is placed.

## **Dynamic Tests**

At present the ultrasonic pulse velocity method is the only one of this type that shows potential for testing concrete strength in situ. It measures the time of travel of an ultrasonic pulse passing through the concrete. It consists of a pulse generator and a pulse receiver.. The time taken for the pulse to pass through the concrete is measured by electronic measuring circuits.

**Applications and Limitations.** The pulse velocity method is an ideal tool for establishing whether concrete is uniform. It can be used on both existing structures and those under construction. Usually, if large differences in pulse velocity are found within a structure for no apparent reason, there is strong reason to presume that defective or deteriorated concrete is present.

High pulse velocity readings are generally indicative of good quality concrete. A general relation between concrete quality and pulse velocity is given in Table below.

General Conditions	Pulse Velocity ft/sec
Excellent	Above 15,000
Good	12,000-15,000
Questionable	10,000-12,000
Poor	7,000-10,000
Very Poor	below 7,000

In summary, ultrasonic pulse velocity tests have a great potential for concrete control, particularly for establishing uniformity and detecting cracks or defects. Its use for predicting strength is much more limited, owing to the large number of variables affecting the relation between strength and pulse velocity.

## 8.5 Dimensional Stability (Creep and Shrinkage).

Dimensional stability of a construction material refers to its dimensional change over a long period of time. If the change is so small that it will not cause any structural problems, the material is dimensionally stable. For concrete, drying shrinkage and creep are two phenomena that compromise its dimensional stability

### 8.5.1 Creep of Concrete

Creep is time dependent deformations of concrete under permanent loads (self-weight). When concrete is subjected to compressive loading it deforms instantaneously. This immediate deformation is called instantaneous strain.

Now, if the load is maintained for a considerable period of time, concrete undergoes additional deformations even without any increase in the load. This time-dependent strain is termed as creep.

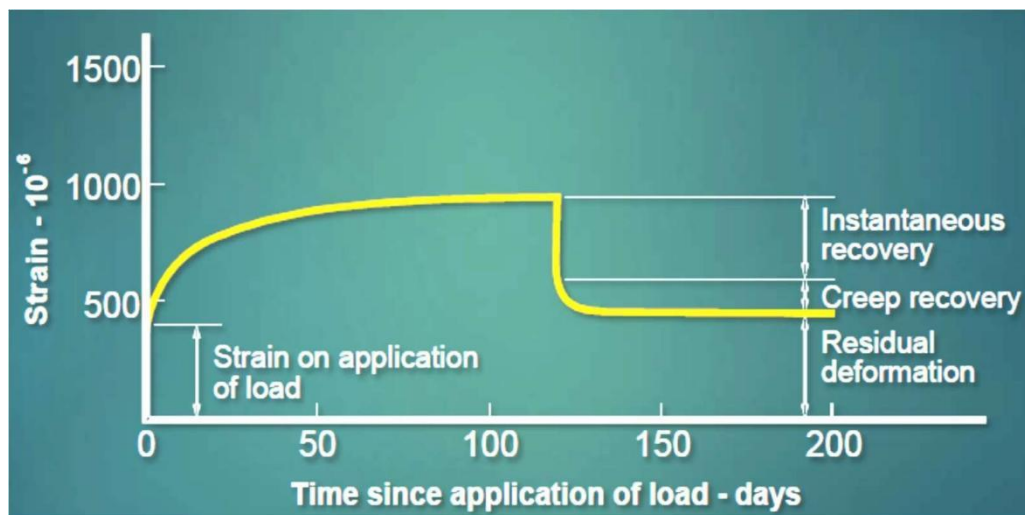

- The ability of concrete to creep imparts a degree of ductility to concrete that enables it to tolerate the normal range of structural deformations encountered in practice. Creep provides a structure with the ability to redistribute excessive stresses.
- However, creep also may have detrimental effects such as increased deflection resulting in cracking, loss of pre-stress, and buckling of slender columns.
- In reinforced concrete beams, creep increases the deflection with time and may be a critical consideration in design. In eccentrically loaded columns, creep increases the deflection and can lead to buckling.

- Due to the delayed effects of creep, the long-term deflection of a beam can be 2-3 times larger than the initial deflection.
- It is therefore important that the designer takes the necessary steps to allow for creep in the design of concrete structures.

## 8.5.2 Shrinkage of Concrete

Shrinkage of concrete is caused by the following causes:

- Settlement of solids and the loss of free water from the plastic concrete (**plastic shrinkage**),
- Chemical combination of cement with water (**autogenous shrinkage**) and
- Drying concrete (**drying shrinkage**).

### 1- Plastic Shrinkage

Shrinkage, which takes place before concrete has set, is known as plastic shrinkage. It occurs as a result of the loss of free water and the settlement of solids in the mix.

Plastic shrinkage is most common in slab construction and is characterized by the appearance of surface cracks which can extend quite deeply into the concrete.

**Preventive measures**: reduce water loss by any curing methods (cover concrete with wet polythene sheets or by spraying a membrane-curing compound).

### 2- Autogenous Shrinkage

As hydration continues in an environment where the water content is constant, such as inside a large mass of concrete, this decrease in volume of the cement paste results in shrinkage of the concrete. This is known as **autogenous shrinkage**; it is self-produced by the hydration of cement.

### 3- Drying Shrinkage

When a hardened concrete, cured in water, is allowed to dry it first loses water from its voids and capillary pores and only starts to shrink during further drying when water is drawn, out of its cement gel. This is known as **drying shrinkage**.

After an initial high rate of drying shrinkage concrete continues to shrink for a long period of time, but at a continuously decreasing rate.

## Cracking Mechanism:

If the tensile stress induced by restrained shrinkage exceeds the tensile strength of concrete, cracking will take place in the restrained structural element. If shrinkage cracks are not properly controlled, they permit the passage of water, expose steel reinforcements to the atmosphere, reduce shear strength of the member and are bad for appearance of the structure.

Shrinkage cracking is often controlled with the incorporation of sufficient reinforcing steel, or the provision of joints to allow movement.

## Factors Affecting Drying Shrinkage

- Type, content and proportion of the constituent materials of concrete (cement, water, aggregates, etc.),
- Size and shape of the concrete structure,
- Amount and distribution of reinforcement,
- Relative humidity of the environment.

Drying shrinkage is directly proportional to the water-cement ratio and inversely proportional to the aggregate-cement ratio (Figure below).

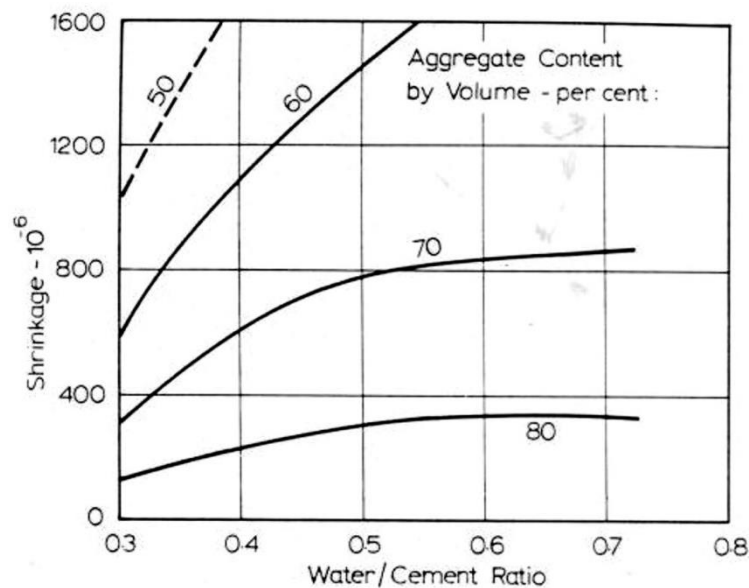

Figure. Influence of water/cement ratio and aggregate content on shrinkage

Because of the interaction of the effects of aggregate-cement and water-cement ratios, it is possible to have a rich mix with a low water-cement ratio giving higher shrinkage than a leaner mix with a higher water-cement ratio.

## 8.6 Durability of Concrete



### 8.6.1 Definitions

- Durability is the ability of concrete to withstand the conditions for which it is designed without deterioration for a long period of years.
- Durability of concrete may be defined as the ability of concrete to resist weathering action, chemical attack, and abrasion while maintaining its desired engineering properties.
- Durability is defined as the capability of concrete to resist weathering action, chemical attack and abrasion while maintaining its desired engineering properties.

Different concretes require different degrees of durability depending on the exposure environment and properties desired. For example, concrete exposed to tidal seawater will have different requirements than indoor concrete.

## Concrete will remain durable if:

- The cement paste structure is dense and of low permeability.
- It is made with graded aggregate that are strong and inert.
- The ingredients in the mix contain minimum impurities such as alkalis, Chlorides, sulphates and silt.

### 8.6.2 Factors affecting durability of concrete

Durability of Concrete is influenced by the factors shown in the following figure

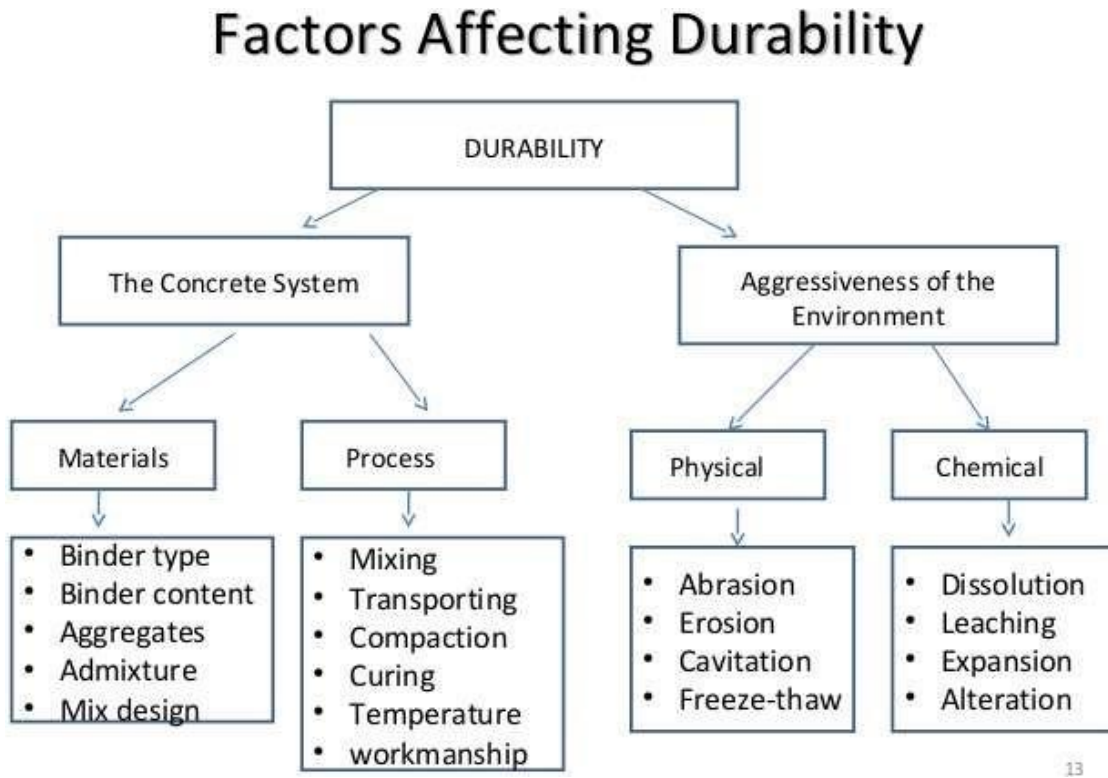

### Other factors are:

#### 1- Concrete Cover

Thickness of concrete cover must follow the limits set in codes.

#### 2- Permeability

It is considered the most important factor for durability. It can be noticed that higher permeability is usually caused by higher porosity. Therefore, a proper curing, sufficient cement, proper compaction and suitable concrete cover could provide a low permeability concrete.

Permeability of water into concrete expand its volume and lead to formation of cracks and finally disintegration of concrete occurs. To prevent permeability, lowest possible water cement ratio must be recommended. Use of pozzolanic materials also helps to reduce permeability by filling capillary cavities.

### **3- Carbonation**

When moist concrete is exposed to atmosphere, carbon dioxide present in atmosphere reacts with concrete and reduces pH of concrete. When pH of concrete reaches below 10, reinforcement present in the concrete starts corroding. Corrosion of reinforcement causes cracks in concrete and deterioration takes place.

#### **8.7 Types of Durability**

There are many types but the major ones are:

- 1. Chemical durability of concrete.**
- 2. Physical durability of concrete.**

##### **8.7.1 Chemical Durability**

When dealing with durability, chemical attack which results in volume change, cracking and consequent deterioration of concrete become a major cause of concern. Types of the chemical attacks are as follows:

- Sulphate attack
- Alkali aggregate reaction
- Chloride ion attack - Corrosion
- Carbonation
- Acid Attack
- Effect on concrete in Seawater

##### **1. Sulphate attack**

- Sulphate attack denotes an increase in the volume of cement paste in concrete or mortar due to chemical action between the products of hydration of cement and solution containing sulphate, and also sodium, magnesium and Chlorides.
- In hardened concrete, calcium aluminate hydrate (CAH) can react with sulphate salt from outside, product of reaction is calcium sulphoaluminate, which can cause an increase in volume up to 227%
- Rate of sulphate attack increases with a saturated sulphate solution.
- A saturate solution of magnesium sulphate can cause serious damage to concrete with high w/c ratio.

## **Methods of controlling sulphate attack**

- Use SRC (sulphate resisting cement)
- Quality concrete - low w/c ratio, well designed and compacted dense concrete
- Use of air-entrainment
- Use of puzzolana
- Use of high alumina cement

## **2. Alkali - Aggregate Reaction**

Alkali-aggregate reaction (AAR) is basically a chemical reaction between the hydroxyl ions in the pore water within concrete and certain types of rock minerals. Since reactive silica in the aggregate is involved in this chemical reaction it is often called alkali-silica reaction (ASR). It is recognized as one of the major causes of cracking of concrete.

Its occurrence is due to :

1. High alkali content in cement (more than 0.6%)
2. Reactive silica in aggregate
3. Availability of moisture

### **Remedial Measures:**

1. Use non-reactive aggregates from alternate sources
2. Use low-alkali cement
3. Reduce cement content in concrete.

## **3. Chlorides in Concrete.**

- Chlorides in concrete increases risk of corrosion of steel (Electrochemical reaction)
- Higher Chloride content or exposure to warm moist conditions increase the risk of corrosion.
- To minimize the chances of corrosion, the levels of chlorides in concrete should be limited
- Total amount of chloride content (as Cl) in concrete at the time of placing is provided by common specifications and standards.

### **Methods of Controlling Chlorides**

1. Chlorides in cement to be less than 0.1 % max (or 0.05% max for prestressed works)
2. Chlorides in water to be less than 2000 mg/ltr for PCC and below 500 mg/ltr for RCC

3. Chlorides in aggregates are generally not encountered but, it's a good practice to wash sand containing salt more than 3%
4. Chloride traces are also found in chemical admixtures. Chloride free admixtures should be generally preferred.

#### **4. Carbonation of Concrete**

Carbonation of concrete is a process by which carbon dioxide from the air penetrates into concrete and reacts with calcium hydroxide to form calcium carbonates.

In actual practice, CO<sub>2</sub> present in atmosphere permeates into concrete and carbonates the concrete and reduces the alkalinity of concrete.

When all the Ca(OH)<sub>2</sub> has become carbonated, the pH value will reduce up to about 8.3. In such a low pH value, the protective layer gets destroyed and the steel is exposed to corrosion.

Rate of Carbonation depends upon relative humidity, grade of concrete, permeability of concrete, depth of cover and time

Protective coating is required to be given for long span bridge girders, flyovers, Industrial structures and chimneys. Such as plastic paints (Impermeable). Deep cover plays an important role in protecting the steel from carbonation.

#### **8.7.2 Physical Durability**

Physical durability is against the following actions:

1. Freezing and thawing action.
2. Percolation / Permeability of water.
3. Temperature stresses i.e. high heat of hydration.

## Chapter 7: Concrete Mix Design

### 7.1 Definitions

**Mix design** is the process of determining required and specified characteristics of a concrete mixture. Characteristics can include: (1) fresh concrete properties; (2) required mechanical properties of hardened concrete such as **strength** and **durability** requirements; and (3) the inclusion, exclusion, or limits on specific ingredients. Mix design leads to the development of a concrete specification.

**Mixture proportioning** refers to the process of determining the quantities of concrete ingredients, using local materials, to achieve the specified characteristics of the concrete. A properly proportioned concrete mix should possess these qualities:

1. Acceptable workability of the freshly mixed concrete
2. Durability, strength, and uniform appearance of the hardened concrete
3. Economy

**Mixture proportioning** is a process of selecting suitable ingredients and determining their relative proportions with the objective of producing concrete having certain minimum workability, strength and durability as economically as possible.

**Mixture proportioning** is to determine the most economical and practical combination of readily available materials to produce a concrete that will satisfy the performance requirements under particular conditions of use.

### 7.2 Factors to be Considered Mix Proportioning:

- Required workability (Cohesiveness, slump) based on placement conditions.
- Strength and durability.
- Appearance.
- Economy.
- Minimize the amount of cement, Minimize w/c ratio.
- Minimum amount of water, to reduce cement content.
- do not sacrifice the quality.

### Advantages of low water/cement ratio:

- Increased strength.
- Lower permeability.
- Increased resistance to weathering.
- Better bond between concrete and reinforcement.
- Reduced drying shrinkage and cracking.
- Less volume change from wetting and drying.

### **7.3 Basic data required for mix proportioning.**

The following basic data is required for concrete mix proportioning:

- (i) **Grade designation:** It gives characteristic compressive strength of concrete. The target mean strength of concrete is fixed by adding a suitable margin to the characteristic strength depending upon the quality control to be envisaged.
- (ii) **Type of cement:** The type and grade of cement mainly influences the rate of development of compressive strength of concrete.
- (iii) **Maximum nominal size of aggregate:** The maximum nominal size of the aggregate to be used in concrete is governed by the size of the section to be concreted and spacing of the reinforcement.
- (iv) **Maximum water-cement ratio:** The maximum water cement ratio to be used for a particular work is governed by the desired strength and limited by the durability requirements.
- (v) **Minimum cement content:** The minimum cement content to be used is governed by the respective environmental exposure conditions.
- (vi) **Workability:** The desired workability for a particular job depends upon the shape and size of section to be concreted, denseness of reinforcement, and method of transportation, placing and compaction of concrete.
- (vii) **Exposure conditions:** The anticipated environmental exposure conditions in which the structure is intended to serve during its service span defines the durability requirements.
- (viii) **Type and properties of aggregate:** It influences the workability and strength of concrete. The relative proportions of coarse and fine aggregate are determined from the characteristics of the aggregates such as grading, shape, size and surface texture.
- (ix) **Method of transporting and placing:** It influences workability of the mix.
- (x) **Use of admixtures:** Admixtures are used to enhance and modify one or more properties of concrete in fresh as well as hardened state.

### **7.4 Compressive Strength Grading and Classes**

**Grade of Concrete** is the classification of concrete according to its compressive strength.

#### **7.4.1 Indian Standards:**

There are different grades of concrete are given as M10, M15, M20, M25, M30, M35 and M40. The letter "M" denotes Mix design with proportion of materials like Cement: Fine Aggregate: Coarse Aggregate.

The Numbers represent the predetermined cube strength of 15cm cube after curing of 28 days in N/mm<sup>2</sup>.

M10 = 10N/mm<sup>2</sup> compressive strength after 28days.

M15 = 15N/mm<sup>2</sup> compressive strength after 28days.

M20 = 20N/mm<sup>2</sup> compressive strength after 28days.

### Nominal Grades

Grade of Concrete	Mix Ratio	Compressive Strength in N/mm <sup>2</sup> or MPa	Compressive Strength in Psi
M5	1 : 5 : 10	5 MPa	725 psi
M7.5	1 : 4 : 8	7.5 MPa	1087 psi
M10	1 : 3 : 6	10 MPa	1450 psi
M15	1 : 2 : 4	15 MPa	2175 psi
M20	1 : 1.5 : 3	20 MPa	2900 psi

### 2. Standard Grades

M25	1 : 1 : 2	25 MPa	3625 psi
M30	Design Mix	30 MPa	4350 psi
M35	Design Mix	35 MPa	5075 psi
M40	Design Mix	40 MPa	5800 psi
M45	Design Mix	45 MPa	6525 psi

### 3. High Strength Grades

M50	Design Mix	50 MPa	7250 psi
M55	Design Mix	55 MPa	7975 psi
M60	Design Mix	60 MPa	8700 psi
M65	Design Mix	65 MPa	9425 psi
M70	Design Mix	70 MPa	10150 psi
M80	Design Mix	80 MPa	11600 psi
M90	Design Mix	90 MPa	13050 psi
M100	Design Mix	100 MPa	14500 psi
M150	Design Mix	150 MPa	21750 psi
M200	Design Mix	200 MPa	29000 psi

## 7.4.2 European Standard EN206-1 Part 1: Specification, performance, production and conformity

Concrete in EN206-1 is classified with respect to its compressive strength. The characteristic compressive strength at 28 days of 150 mm diameter by 300 mm cylinders or the characteristic compressive strength at 28 days of 150 mm cubes may be used for classification.

**Table 7 – Compressive strength classes for normal-weight and heavy-weight concrete**

Compressive strength class	Minimum characteristic cylinder strength	Minimum characteristic cube strength
	$f_{ck,cyl}$ N/mm <sup>2</sup>	$f_{ck,cube}$ N/mm <sup>2</sup>
C8/10	8	10
C12/15	12	15
C16/20	16	20
C20/25	20	25
C25/30	25	30
C30/37	30	37
C35/45	35	45
C40/50	40	50
C45/55	45	55
C50/60	50	60
C55/67	55	67
C60/75	60	75
C70/85	70	85
C80/95	80	95
C90/105	90	105
C100/115	100	115

## 7.5 Characteristic Strength and Target Mean Strength

The strength of concrete produced in sites is varied between mixes and even in in the same mix. The overall variation in the measured strength of concrete that is obtained during a job can be considered to be made up of three component sources which are:

1. Variations in testing methods.
2. Variations in the properties or proportions of the constituent materials in the concrete mixture, variations in the production, delivery or handling procedures, and variations in climatic conditions.

Variation in concrete strengths follows the normal distribution such as that shown below

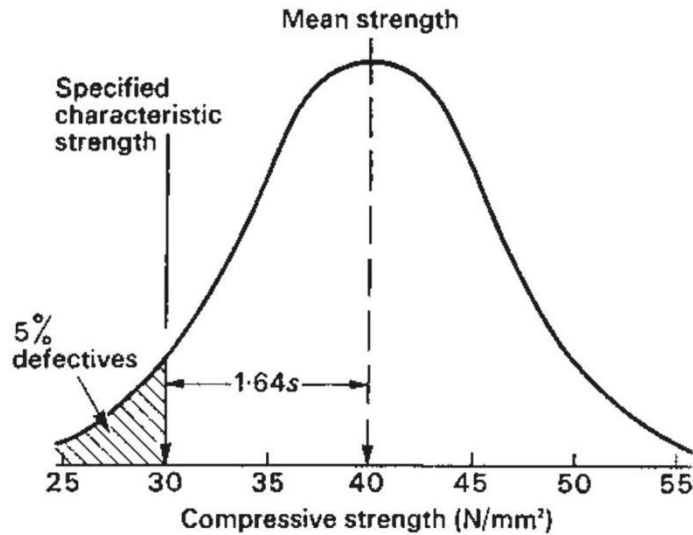

**Figure: Normal distribution of concrete strengths**

This normal distribution curve is symmetrical about its mean, has a precise mathematical equation and is completely specified by two parameters, its mean “m” and its standard deviation “s”. Concrete cube strengths follow the normal distribution. There is therefore always the probability that a result will be obtained less than the specified strength.

The proportion of results less than some specified value is represented by the area beneath the curve to the left-hand side of a vertical line drawn through the specified value.

**Standard deviation:** The standard deviation is a measure of the variability calculated from the equation:

$$s = \sqrt{\frac{\sum (x_i - \bar{x})^2}{n - 1}}$$

$x_i$  = individual test result.  
 $\bar{x}$  = average strength results.  
 $n$  = number of results.

Standard deviation increases as the specified characteristic strength increases up to a particular level. This type of relationship is shown below, the standard deviation being independent of the specified characteristic strength above 20 N/mm<sup>2</sup>.

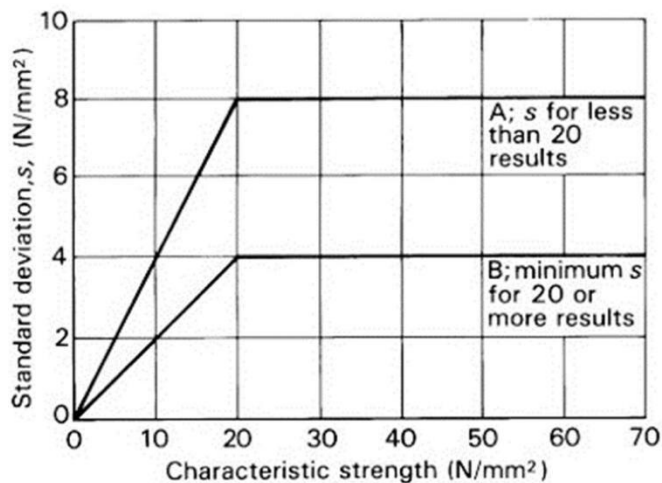

**Figure A.** Relationship between standard deviation and characteristic strength.

**d) Coefficient of variation:** It is an alternative method of expressing the variation of results. It is a non-dimensional measure of variation obtained by dividing the standard deviation by the arithmetic mean and is expressed as:

$$C_v \% = \frac{\sigma}{\bar{x}} * 100$$

### **Characteristic Strength**

The quality of concrete is specified '**characteristic strength**' below which a specified proportion of the test results, often called 'defectives', may be expected to fall. The characteristic strength could be the minimum design value which applied in the design of various structural elements and specified in the project specifications.

**Based on EN 206-1:** the value of strength below which 5 % of the population (number of test results) of all possible strength determinations of the volume of concrete under consideration, are expected to fall.

### **Target Mean Strength**

The producer of concrete should design the concrete mix using a higher strength than that of the characteristic strength by a certain **Margin** (risk factor), in order to ensure satisfying the quality criteria set by the client. This higher strength is called **Target Mean Strength**.

Target mean strength = specified characteristic strength + Margin

$$\text{Target mean strength} = f_{ck}$$

$$\text{Specified characteristic strength} = f_{ck}$$

$$\text{Margin} = k \cdot \sigma$$

$$f_{td} = f_{ck} + k \cdot \sigma$$

The constant **k** is derived from the mathematics of the normal distribution and increases as the proportion of defectives is decreased, thus:

$$k \text{ for } 10\% \text{ defectives} = 1.28$$

$$k \text{ for } 5\% \text{ defectives} = 1.65$$

$$k \text{ for } 2.5\% \text{ defectives} = 1.96$$

$$k \text{ for } 1\% \text{ defectives} = 2.33$$

## **7.6 Methods of Concrete Mix design**

Most of available methods of concrete mix design are based on empirical relationships, charts, graphs developed from intensive experimental programs. Basically, they follow the same principles and only minor changes exist in different mix design methods in selecting the mix proportions.

The requirements of the concrete mix is usually identified by the general experience with regard to the structural design conditions, durability and conditions of placing. Some of the commonly used mix design methods for medium strength concrete are the following:

- **Trial and adjustment method of mix design.**
- **British DoE mix design method.**
- **ACI mix design method.**
- **Indian standard Recommended method IS 10262-82**

### **7.7 British Method of Concrete Mix Design (DoE Method)**

The DOE method was first published in 1975 and then revised in 1988. While Road Note No 4 or Grading Curve Method was specifically developed for concrete pavements, the DOE method is applicable to concrete for most purposes, including roads. The method can be used for concrete containing fly ash or GGBFS. The following are the steps involved in DOE method:

#### **Step 1: Find Target Mean Strength**

Find the **target mean strength** as explained before.

#### **Step 2: Calculation of Water/Cement Ratio**

This is done in a rather round about method, using Table 1 and Figure. 1.

**Table 1: Approximate compressive strengths (MPa) of concrete mixes made with a free-water/cement ratio of 0.5**

Cement strength class	Type of coarse aggregate	Compressive strengths (N/mm <sup>2</sup> )			
		Age (days)			
		3	7	28	91
42.5	Uncrushed	22	30	42	49
	Crushed	27	36	49	56
52.5	Uncrushed	29	37	48	54
	Crushed	34	43	55	61

Throughout this publication concrete strength is expressed in the units N/mm<sup>2</sup>.  
1 N/mm<sup>2</sup> = 1 MN/m<sup>2</sup> = 1 MPa. (N = newton; Pa = pascal.)

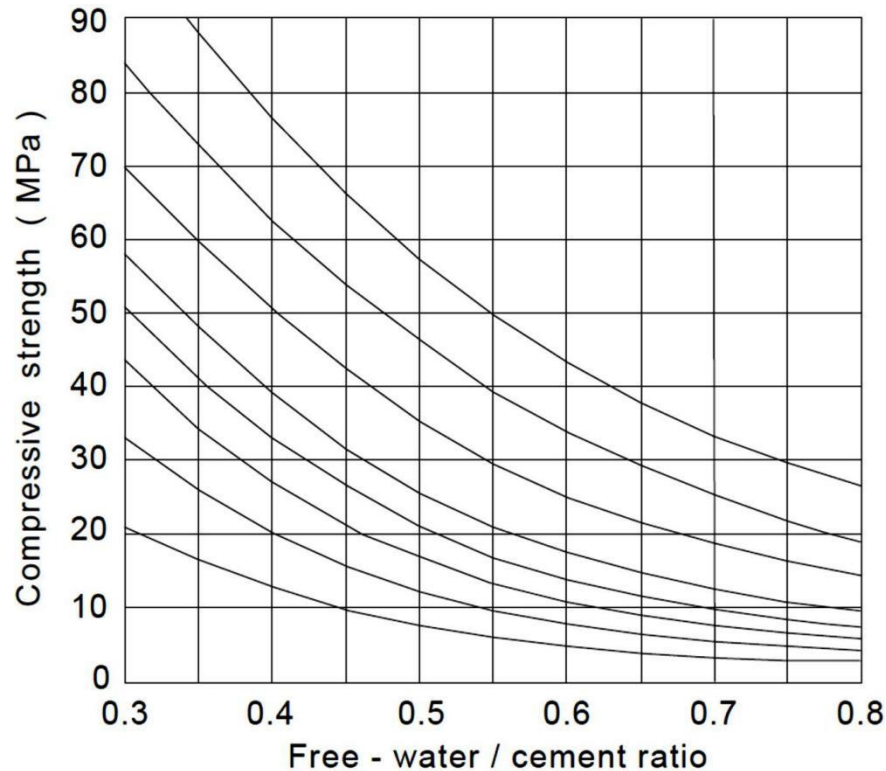

**Figure 1** Relation between compressive strength and free-water/cement ratio

It is required to find the w/c for the 28 days compressive strength is 39 MPa. Referring to Table 1, for OPC, crushed aggregate, W/C ratio of 0.5, the 28 days compressive strength is 49 MPa. In Fig. 1 find an intersection point for 49 MPa and 0.5 W/C ratio. Draw a dotted line curve parallel to the neighboring curve. From this curve read off the W/C ratio for a target mean strength of 39 MPa. The Water/cement ratio is = 0.58.

**Check this W/C ratio from durability consideration from Table B. Adopt lower of the two ratios.**

**Table B.** requirements of BS 8110: Part I: 1985 to Ensure Durability Under Specified Exposure Conditions of Reinforced and Prestressed Concrete Made with Normal Weight Aggregate.

<i>Condition of exposure</i>	<i>Nominal Cover of Concrete in mm</i>				
Mild	25	20	20	20	20
Moderate	-	35	30	25	20
Severe	-	-	40	30	25
Very Severe	-	-	50	40	30
Extreme	-	-	-	60	50
Maximum Water/ Cementitious material ratio	0.65	0.60	0.55	0.50	0.45
Minimum content of cementitious Material in kg/m <sup>3</sup>	275	300	325	350	400
Minimum grade MPa	30	35	40	45	50

### Step 03: Calculation of free Water Content

Table 2 Approximate free-water contents (kg/m<sup>3</sup>) required to give various levels of workability

Slump (mm)		0-10	10-30	30-60	60-180
Vebe time (s)		>12	6-12	3-6	0-3
.....					
Maximum size					
of aggregate (mm)	Type of aggregate				
10	Uncrushed	150	180	205	225
	Crushed	180	205	230	250
20	Uncrushed	135	160	180	195
	Crushed	170	190	210	225
40	Uncrushed	115	140	160	175
	Crushed	155	175	190	205

For example: for uncrushed aggregate, MSA = 20 mm, slump from 30-60 mm, w/c ratio = 0.50, the Mixing water content is 180 kg/m<sup>3</sup> of concrete.

### Step 04: Calculation of cement Content

$$w/c = \frac{w}{c}, \text{ cement content, } c = \frac{w}{w/c}$$

The calculated cement content should be compared with any given minimum cement content.

### Step 05: Weight of Total Aggregate

This requires an estimate of the wet density of the fully compacted concrete. This can be found out from Figure below for approximate water content and specific gravity of aggregate. An approximation can be made by assuming an average value of specific gravity of **2.6 for uncrushed** aggregate and **2.7 for crushed aggregate**.

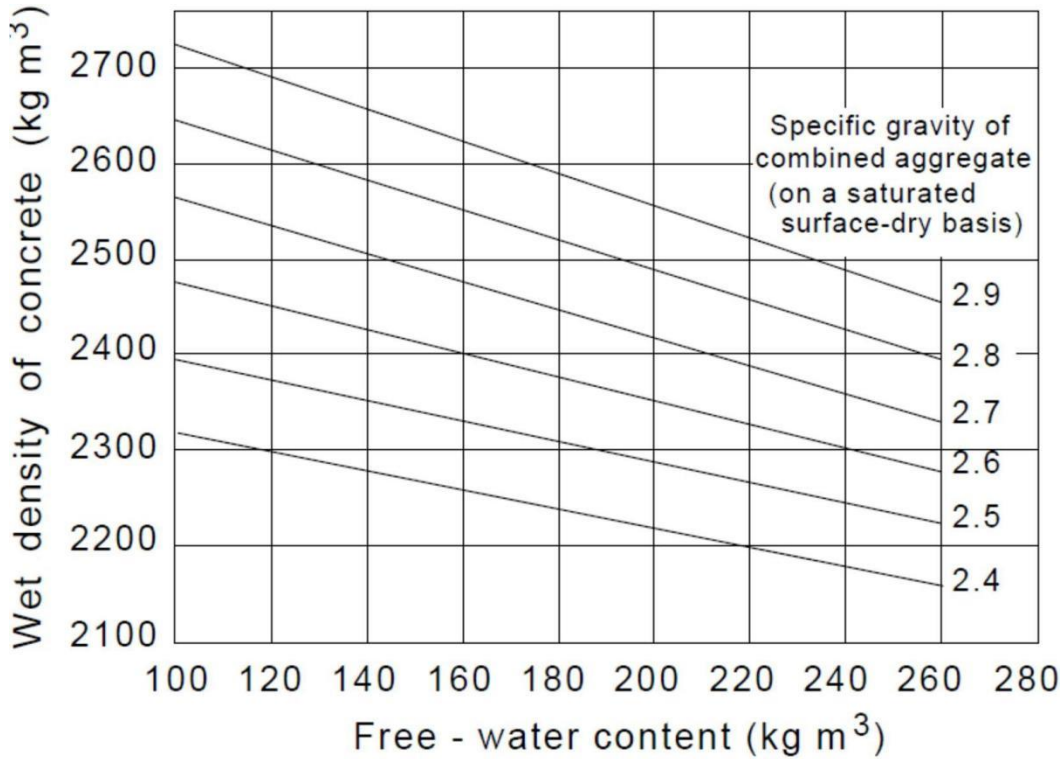

Figure 2 Wet density of fully compacted concrete

Estimated wet density of fully compacted concrete.

Then, total weight of aggregate is find out:

$$W_{agg} = \frac{W_{concrete} - [W_{cement} + W_{water}]}{G_{agg}}$$

### **Step 06: Weight of Fine Aggregate**

Then, proportion of fine aggregate is determined in the total aggregate using Figure above. Figure (a) is for 10 mm size, (b) is for 20 mm size and (c) is for 40 mm size coarse aggregate.

The parameters involved are

- maximum size of coarse aggregate,
- the level of workability,
- water/cement ratio, and
- Fineness Modulus (FM).

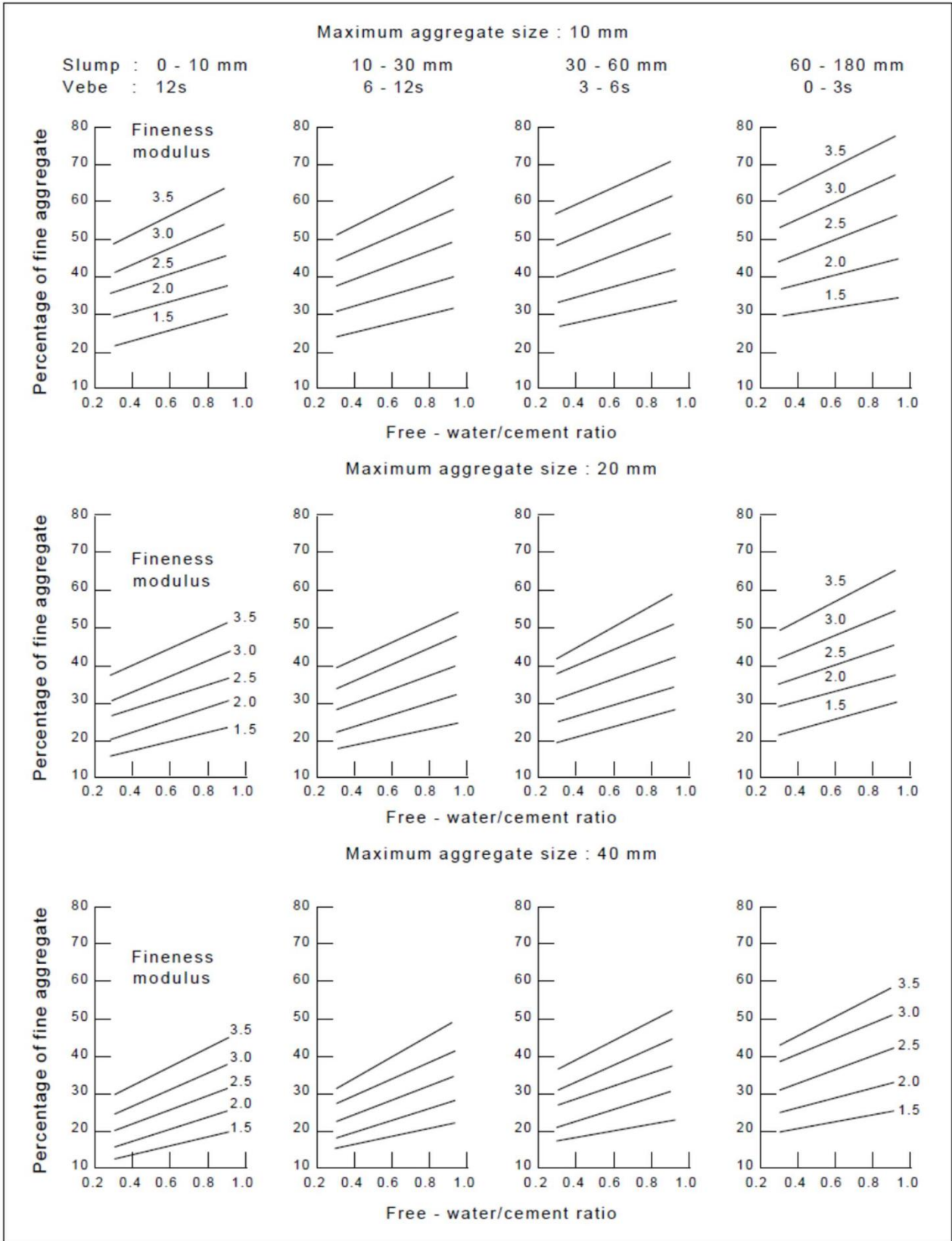

**Figure 3 Proportions of fine aggregate determined from Fineness Modulus**

For example: for 20 mm aggregate size, w/c ratio of 0.50, Slump of 75 mm, for FM=2.5, the %  $\approx 39\%$

Then:

Fine aggregate content = total aggregate content × % wt of fine aggregates..

Coarse aggregate content = total aggregate content – fine aggregate content.

Coarse aggregate content can be subdivided if single sized 10, 20 and 40 mm aggregates are to be combined. The best proportions will depend on aggregate shape and concrete usage, but the following ratios are suggested as a guide:

1: 2 for combination of 10mm and 20mm aggregates.

1 :1.5 : 3 for combination of 10mm, 20mm and 40 mm aggregates.

### **Step 07: Trial Mixes**

The design procedure outlined above is based on materials which may not be what is used for your design. It is unlikely that the first mix design would achieve the target results. It usually takes a few trials before a satisfactory design is achieved.

After each trial mix, the concrete mix design should be adjusted before the next trial. The following items may be given consideration:

**Density:** The density of the concrete measured during the trial mix should be checked against the assumed density during the mix design, and necessary adjustments should be made accordingly.

**Slump:** The slump can be adjusted by adjusting the water content and the fine aggregate/coarse aggregate ratio. Slump can be increased by increasing the water content and/or decreasing the fine aggregate/coarse aggregate ratio. A slump adjustment of 20 mm can be achieved by changing the water content by 5 kg and fine aggregate by 5 kg. The water/cement ratio should be maintained so that the strength is not altered.

**Strength:** The strength can be adjusted by adjusting the water/cement ratio according to the Figure 1. Use the results from the trial mix, the water/cement ratio and the strength, and plot a point in Figure 1. Draw the curve parallel to the other curves through the point, and use this curve to estimate the water/cement ratio required for the target strength.

### **Step 08. Adjustments for Aggregate Weights and Water Content.**

- 1- The **effective absorption (EA)** represents the amount of water required to bring an aggregate from the AD state to the SSD, expressed as a fraction of the SSD weight:

$$EA = (W_{SSD} - W_{AD}) / W_{SSD} \times 100\%$$

- 2- The surface moisture (SM) represents water in excess of the SSD state, also expressed as a fraction of the SSD weight:

$$SM = (W_{wet} - W_{SSD}) / W_{SSD} \times 100\%$$

**Aggregate weights.** Aggregate volumes are calculated based on oven dry unit weights, but aggregate is typically batched based on actual weight. Therefore, any moisture in the aggregate will increase its weight and stockpiled aggregates almost always contain some moisture. Without correcting for this, the batched aggregate volumes will be incorrect.

**Amount of mixing water.** If the batched aggregate is anything but saturated surface dry it will absorb water (if oven dry or air dry) or give up water (if wet) to the cement paste. This causes a net change in the amount of water available in the mix and must be compensated for by adjusting the amount of mixing water added.

**Example 1**

Design a concrete mix to obtain a characteristic compressive strength ( $f_c$ ) = 30 N/mm<sup>2</sup> at 28 days, with a 2.5% defective rate ( $k = 1.96$ ), assume that less than 20 previous results are available for calculating the standard deviation. The design requirements are as follows:

- Slump required = 10–30 mm.
- the Maximum aggregate size, MSA = 20 mm (uncrushed),
- Fine aggregate: Fineness modulus, FM =2.5.
- Portland cement class = 42.5.
- maximum free-w/c ratio = 0.55,
- minimum cement content = 290 kg/m<sup>3</sup>,
- maximum cement content = not specified.

Absorption of fine aggregate = 2%; Absorption of coarse aggregate = 1.1%

Total Moisture content of coarse aggregate = 2.5%; Total Moisture content of fine aggregate = 1.5%.

What are the proportions to produce trial mix of 0.05 m<sup>3</sup> concrete?

What are the proportions to produce 25 m<sup>3</sup> concrete?

**Step 1: Find Target Mean Strength**

Find the **target mean strength.**

Target mean strength =  $f_{cm}$

Specified characteristic strength =  $f_{ck}$ , Margin =  $k \cdot \sigma$

From Figure A. the standard deviation is 8 MPa

$$f_{cm} = f_{ck} + k \cdot \sigma$$

$$f_{cm} = 30 + 1.96 \cdot 8 = 45.7 \text{ MPa}$$

**Step 2: Calculation of Water/Cement Ratio**

From Table 1 the compressive strength for w/c =0.50 is 42MPa. From Figure 1 the w/c for compressive strength of 45.7 MPA is **0.47**.

### Step 03: Calculation of free Water Content

From Table 2, for 10-30mm level of workability, uncrushed aggregates and maximum aggregate size of 20mm the water content is **160kg/m<sup>3</sup>** concrete.

### Step 04: Calculation of cement Content

$$w/c = \frac{w}{c}, \text{ cement content, } c = \frac{160}{0.47} = 340 \frac{\text{kg}}{\text{m}^3}$$

### Step 05: Weight of Total Aggregate

From Figure 2 for free water content of **160 kg/m<sup>3</sup>**, Specific gravity of Uncrushed aggregates =2.6 (assumed), the wet density of concrete = **2400 kg/m<sup>3</sup>**. Therefore, the total aggregate content is

$$\begin{aligned} \text{Total aggregate content} &= \text{Wet density of } 1\text{m}^3 \text{ concrete} - \text{water content} - \text{cement content} \\ &= 2400 - 160 - 340 = \mathbf{1900 \text{ kg/m}^3} \end{aligned}$$

### Step 06: Weight of Fine Aggregate

From Figure 3. The workability level =10-30mm, FM=2.5, w/c=0.47, MSA=20mm the percentage of fine aggregates = 32%.

$$\text{Fine aggregate content} = 1900 \times 0.32 = \mathbf{608 \text{ kg/m}^3 \text{ concrete}}$$

$$\text{Coarse aggregate content} = 1900 - 608 = \mathbf{1292 \text{ kg/m}^3 \text{ concrete}}$$

### Step 08. Adjustments for Aggregate Weights and Water Content.

#### Adjusted Fine Aggregate weight.

Total moisture of fine aggregates = 1.5%, and absorption = 2%,

So, the aggregates are in **Air dry condition**,

$$0.5\% = W_w / W_{SSD}, W_w = \text{weight of water to reach SSD} = 0.5\% * 608 = 3.04 \text{ kg.}$$

$$\text{Adjusted weight of fine aggregates} = 608 - 3.04 = \mathbf{605 \text{ kg}}$$

The mixing water should be increased by an amount of 3.04 kg

#### Adjusted Coarse Aggregates weight

Total moisture content of coarse aggregate = 2.5 %, and absorption of coarse aggregate = 1.1%, so the coarse aggregates are in **Wet condition** and there is moisture on the aggregates surface.

$$\text{Surface water, SM} = (2.5\% - 1.1\%) = 1.4\% = W_w / W_{SSD} = W_w / 1292,$$

$$\text{SM} = 1.4\% * 1292/100 = 18.1 \text{ kg}$$

$$\text{Adjusted coarse aggregates, CA} = 1292 + 18.1 = 1310.1 \text{ kg.}$$

Also, amount of water from CA to be added to the mixing water = 18.1 kg

### Adjusted Mixing Water

$$\text{Adjusted mixing water} = 160 + 3.04 - 18.1 = 145 \text{ kg.}$$

### Final Results

	Cement (kg)	Water (kg or litre)	Fine aggregate (kg)	Coarse Aggregates (kg)	
				10 mm	20 mm
Per 1m <sup>3</sup> (to nearest 5kg)	340	160	605	1310.1	
				436.7	873.4
	1	0.47	1.78	3.85	
				1.28	2.57
Per 0.05 m <sup>3</sup>	17	8	30.3	21.8	43.7
Per 25 m <sup>3</sup>	8500	4000	15125	10918	21835

### Problem 1.

Calculate the quantities of cement, water, fine aggregate and coarse aggregate per trial mix of 0.08 m<sup>3</sup> for the following specifications:

- Characteristic compressive strength = 15 MPa at 28 days;
- Defective rate = 5%;
- Cement = Cement strength class 42.5;
- Slump required = 30-60 mm;
- Max. Aggregate size = 40 mm;
- Coarse aggregate (crushed) (10, 20 and 40 mm),
- fine aggregate (crushed), FM= 2.25
- Specific gravity of aggregates = 2.50;
- Maximum allowable free – water/cement ratio = 0.50;
- Minimum allowable cement content = 290 kg/m<sup>3</sup>

### Problem 2.

Calculate the quantities of cement, water, fine aggregate and coarse aggregate per trial mix of 0.08 m<sup>3</sup> for the following specifications.

- Characteristic compressive strength = 50 MPa at 28 days; Defective rate = 1%;
- Cement strength class 42.5; Slump required = 30-60 mm;
- Max. Aggregate size = 10 mm;
- Coarse aggregate (crushed) (10 mm),
- fine aggregate (crushed), FM= 2.5
- Maximum allowable free – water/cement ratio = 0.50; Maximum allowable cement content = 550 kg/m<sup>3</sup>

## **7.8 ACI Mix Design Method**

The ACI Standard 211.1 is a “*Recommended Practice for Selecting Proportions for Concrete*”. The procedure is as follows:

**Step 1. Choice of slump**

**Step 2. Choice of maximum size of aggregate**

**Step 3. Estimation of mixing water and air content**

**Step 4. Selection of water/cement ratio**

**Step 5. Calculation of cement content**

**Step 6. Estimation of coarse aggregate content**

**Step 7. Estimation of Fine Aggregate Content**

**Step 8. Adjustments for Aggregate Moisture**

**Step 9. Trial Batch Adjustments**

### **Step 1. Choice of slump**

If slump is not specified, a value appropriate for the work can be selected from the Table below, or from any other references.

Type of Construction	Slump	
	(mm)	(inches)
Reinforced foundation walls and footings	25 - 75	1 - 3
Plain footings, caissons and substructure walls	25 - 75	1 - 3
Beams and reinforced walls	25 - 100	1 - 4
Building columns	25 - 100	1 - 4
Pavements and slabs	25 - 75	1 - 3
Mass concrete	25 - 50	1 - 2

### **Step 2. Choice of maximum size of aggregate.**

Concretes with the larger-sized aggregates require less mortar per unit volume of concrete, and of course it is the mortar which contains the most expensive ingredient, cement. Thus the ACI method is based on the principle that the **maximum size of aggregate should be the largest available so long it is consistent with the dimensions of the structure.**

### **Step 3. Estimation of mixing water and air content.**

The ACI Method uses past experience to give a first estimate for the quantity of water per unit volume of concrete required to produce a given slump. The approximate amount of water required for average aggregates is given in Table 1.

**Table 1. Approximate Mixing Water and Air Content Requirements for Different Slumps and Maximum Aggregate Sizes.**

	Mixing Water Quantity in kg/m <sup>3</sup> (lb/yd <sup>3</sup> ) for the listed Nominal Maximum Aggregate Size							
<b>Slump</b>	9.5 mm (0.375 in.)	12.5 mm (0.5 in.)	19 mm (0.75 in.)	25 mm (1 in.)	37.5 mm (1.5 in.)	50 mm (2 in.)	75 mm (3 in.)	100 mm (4 in.)
<b>Non-Air-Entrained</b>								
25 - 50 (1 - 2)	207 (350)	199 (335)	190 (315)	179 (300)	166 (275)	154 (260)	130 (220)	113 (190)
75 - 100 (3 - 4)	228 (385)	216 (365)	205 (340)	193 (325)	181 (300)	169 (285)	145 (245)	124 (210)
150 - 175 (6 - 7)	243 (410)	228 (385)	216 (360)	202 (340)	190 (315)	178 (300)	160 (270)	-
Typical entrapped air (percent)	3	2.5	2	1.5	1	0.5	0.3	0.2
<b>Air-Entrained</b>								
25 - 50 (1 - 2)	181 (305)	175 (295)	168 (280)	160 (270)	148 (250)	142 (240)	122 (205)	107 (180)
75 - 100 (3 - 4)	202 (340)	193 (325)	184 (305)	175 (295)	165 (275)	157 (265)	133 (225)	119 (200)
150 - 175 (6 - 7)	216 (365)	205 (345)	197 (325)	184 (310)	174 (290)	166 (280)	154 (260)	-
<b>Recommended Air Content (percent)</b>								
Mild Exposure	4.5	4.0	3.5	3.0	2.5	2.0	1.5	1.0
Moderate Exposure	6.0	5.5	5.0	4.5	4.5	4.0	3.5	3.0
Severe Exposure	7.5	7.0	6.0	6.0	5.5	5.0	4.5	4.0

### **Step 4. Selection of water/cement ratio.**

The required water/cement ratio is determined by strength, durability and finishability. The appropriate value is chosen from prior testing of a given system of cement and aggregate or a value is chosen from Table 2 and/or Table 3.

Table 2: Water-Cement Ratio and Compressive Strength Relationship

28-Day Compressive Strength in MPa (psi)	Water-cement ratio by weight	
	Non-Air-Entrained	Air-Entrained
41.4 (6000)	0.41	-
34.5 (5000)	0.48	0.40
27.6 (4000)	0.57	0.48
20.7 (3000)	0.68	0.59
13.8 (2000)	0.82	0.74

Table 3. Maximum permissible water/cement ratios for concrete in severe exposures

Type of Structure	Structure wet continuously or frequently exposed to freezing & thawing*	Structure exposed to seawater
Thin sections (railings, curbs, sills, ledges, ornamental work) & sections with less than 1-inch cover over steel	0.45	0.40
All other structures	0.50	0.45

\* Concrete should also be air-entrained.

### **Step 5. Calculation of cement content.**

The amount of cement is fixed by the determinations made in Steps 3 and 4 above.

$$\text{weight of cement} = \frac{\text{weight of water}}{w/c}$$

### **Step 6. Estimation of coarse aggregate content.**

The most economical concrete will have as much as possible space occupied by CA since it will require no cement in the space filled by CA.

Table 4: Volume of Coarse Aggregate per Unit Volume for Different Fine aggregate Fineness Moduli

Nominal Maximum Aggregate Size	Fine Aggregate Fineness Modulus			
	2.40	2.60	2.80	3.00
9.5 mm (0.375 inches)	0.50	0.48	0.46	0.44
12.5 mm (0.5 inches)	0.59	0.57	0.55	0.53
19 mm (0.75 inches)	0.66	0.64	0.62	0.60
25 mm (1 inches)	0.71	0.69	0.67	0.65
37.5 mm (1.5 inches)	0.75	0.73	0.71	0.69
50 mm (2 inches)	0.78	0.76	0.74	0.72

Notes:

1. These values can be increased by up to about 10 percent for pavement applications.
2. Coarse aggregate volumes are based on oven-dry-rodded weights obtained in accordance with ASTM C 29.

### **Step 7. Estimation of Fine Aggregate Content.**

At the completion of Step 6, all ingredients of the concrete have been estimated except the fine aggregate. Its quantity can be determined by difference if the “absolute volume” displaced by the known ingredients-, (i.e., water, air, cement, and coarse aggregate), is subtracted from the unit volume of concrete to obtain the required volume of fine aggregate. Then, once the volumes are known the weights of each ingredient can be calculated from the specific gravities.

### **Step 8. Adjustments for Aggregate Moisture.**

As explained previously

### **Step 9. Trial Batch Adjustments.**

The ACI method is written on the basis that a trial batch of concrete will be prepared in the laboratory, and adjusted to give the desired slump, freedom from segregation, finishability, unit weight, air content and strength.

### **Problem (1)**

The 28-day compressive strength should be 34 MPa, The slump should be between 75 mm and 100 mm and the maximum aggregate size should not exceed 19 mm The properties of the materials are as follows:

- Cement : Type I, specific gravity = 3.15
- Coarse Aggregate: Bulk specific gravity (SSD) = 2.65; absorption capacity = 0.5%; dry-rodded unit weight = 1605 kg/m<sup>3</sup>; surface moisture = 1%
- Fine Aggregate: Bulk specific gravity (SSD) = 2.60; absorption capacity = 1.1%; fineness modulus = 2.70; surface moisture = 3%.

### **Problem (2)**

Repeat problem 1 if the concrete is to be subjected to severe exposure to seawater. Compare the material cost.

### **Problem (3)**

Repeat problem 1 for max. aggregate size of 37.5 mm. Compare the material cost.

### **Problem (4)**

Repeat problem 2 for compressive strength of 41 MPa. Compare the material cost

### **Problem (5)**

Repeat problem 1 for slump value of 40mm. Compare the material cost.

### **Problem (5)**

Repeat problem 1 for fineness modulus of the fine aggregates 3.00. Compare the material cost.



# Concrete Manufacturing Process

The **manufacture** of **concrete** is fairly simple. First, the **cement** (usually Portland **cement**) is prepared. Next, the other ingredients - aggregates (such as sand or gravel), admixtures (chemical additives), any necessary fibers, and water are mixed together with the **cement** to form **concrete**.

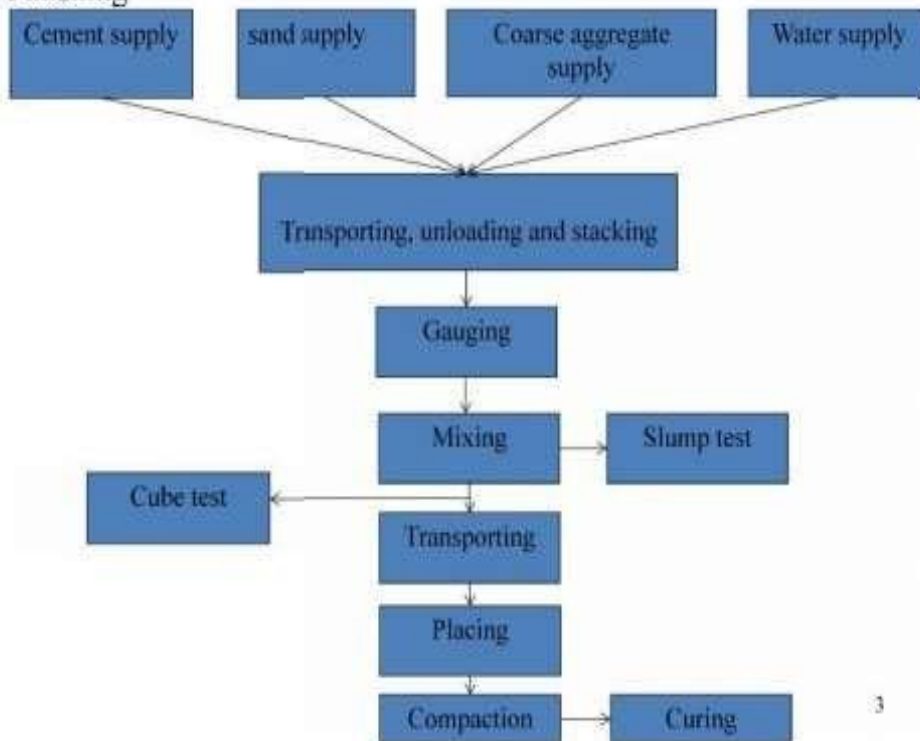



# Concrete Manufacturing Process

## Functions of cement

- It fills up voids existing in the fine aggregate and makes the concrete impermeable.
- It provides strength to concrete on setting and hardening.
- It binds the aggregate into a solid mass by virtue of its setting and hardening properties when mixed with water.

## Functions of sand

- It fills the voids existing in the coarse aggregate.
- It reduces shrinkage and cracking of concrete.
- It helps in hardening of cement by allowing the water through its voids.



# Concrete Manufacturing Process

## Functions of Coarse aggregate

- Coarse aggregate makes solid and hard mass of concrete with cement and sand.
- It increases the crushing strength of concrete.

## Functions of Water

- Water is only the ingredient that reacts chemically with cement and thus setting and hardening takes place.
- Water acts as a lubricant for the aggregate and makes the concrete workable.
- It facilitates the spreading of cement over the fine aggregate.



# Manufacturing process of Concrete

The various stages of manufacture of concrete are:

- Batching
- Mixing
- Transporting
- Placing
- Compacting
- Finishing
- Curing



# Batching

- The measurement of materials for making concrete is known as batching.
- There are two methods of batching:
  - Volume batching
  - Weigh batching



# Volume Batching

- Volume batching is not a good method for proportioning the materials
- Reason: It offers difficulty to measure granular material in terms of volume

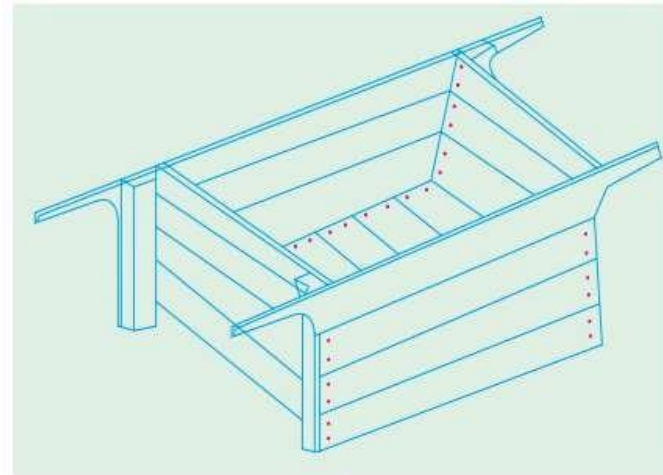

Gauge box



# Weigh Batching

- Weigh batching is the correct method of measuring the materials
- Use of weight system in batching, facilitates accuracy, flexibility and simplicity



Weigh Batcher



# Mixing

- Thorough mixing of the materials is essential for the production of uniform concrete.
- The mixing should ensure that the mass becomes homogeneous, uniform in colour and consistency.
- There are two methods adopted for mixing concrete:
  - Hand Mixing
  - Machine Mixing



# Hand mixing

- Hand mixing - done over an impervious layer
- Spread out the measured quantity of coarse aggregate and fine aggregate in alternate layers
- Pour the cement on the top of it, and mix them until uniformity of colour is achieved.
- This uniform mixture is spread out in thickness of about 20 cm.
- Water is taken and sprinkled over the mixture and simultaneously turned over.
- This operation is continued till such time a good uniform, homogeneous concrete is obtained.
- It is of particular importance to see that the water is not poured but it is only sprinkled.



# Machine Mixing

- Machine mixing is not only efficient, but also economical
- Types of mixers available for mixing concrete
  - Batch-mixers
  - Continuous mixers
- Batch mixers produce concrete, batch by batch with time interval, whereas continuous mixers produce concrete continuously without stoppage till such time the plant is working.
- In normal concrete work, it is the batch mixers that are used.
- Batch mixer may be of pan type or drum type.
- The drum type may be further classified as tilting, non-tilting, reversing or forced action type



# Transporting Concrete

- Concrete can be transported by a variety of methods and equipment
- The precaution to be taken while transporting concrete is that the homogeneity obtained at the time of mixing should be maintained while being transported to the final place of deposition
- The methods adopted for transportation of concrete are:
  - Mortar Pan
  - Wheel Barrow, Hand Cart
  - Crane, Bucket and Rope way Truck Mixer and Dumpers
  - Belt Conveyors
  - Chute
  - Skip and Hoist
  - Transit Mixer
  - Pump and Pipe Line



# Placing Concrete

- It is the process of depositing concrete in its required concrete
- It is not enough that a concrete mix correctly designed, batched, mixed and transported, it is of utmost importance that the concrete must be placed in systematic manner to yield optimum results.



# Compaction of Concrete

- Compaction of concrete is the process adopted for expelling the entrapped air from the concrete.
- In the process of mixing, transporting and placing of concrete air is likely to get entrapped in the concrete.
- The lower the workability, higher is the amount of air entrapped.
- In other words, stiff concrete mix has high percentage of entrapped air and, therefore, would need higher compacting efforts than high workable mixes.
- If this air is not removed fully, the concrete loses strength considerably
- It is imperative that 100 per cent compaction of concrete is one of the most important aim in good concrete-making practices



# Compaction of Concrete

The following methods are adopted for compacting the concrete:

– Hand Compaction

i) Rodding    ii) Ramming    iii) Tamping

– Compaction by Vibration

i. Internal vibrator (Needle vibrator)

ii. Formwork vibrator (External vibrator)

iii. Table vibrator

iv. Platform vibrator

v. Surface vibrator (Screed vibrator)

vi. Vibratory Roller

vii. Compaction by Pressure and Jolting

viii. Compaction by Spinning



# Finishing

- Concrete finish depend upon ultimate use
- Finishing does not apply to all concrete operations.
- For a beam concreting, finishing may not be applicable, whereas for the concrete road pavement, airfield pavement or for the flooring of a domestic building, careful finishing is of great importance
- Finishing may be achieved by following operations
  - Screeding
  - Floating
  - Trowelling



# Curing of Concrete

- Curing can be described as keeping the concrete moist enough so that the hydration of cement can continue.
- Concrete derives its strength by the hydration of cement particles
- The hydration of cement is not a momentary action but a process continuing for long time
- The rate of hydration is fast to start with, but continues over a very long time at a decreasing rate
- The quantity of the product of hydration and consequently the amount of gel formed depends upon the extent of hydration.



# Curing

Curing methods may be divided broadly into four categories:

- Water curing - Immersion, Ponding Spraying or Fogging ,Wet covering
- Membrane curing
- Application of heat
- Miscellaneous